

# SPECIFICATION

## FOR APPROVAL

Customer : Quartz1

---

Product Name : Siren with Strobe Light

---

Model Name : VSL-102-V12R

---

Drawing No. : VS20140227019

---

### Signature of Voice

Approved by	Checkde by	Issued by	Date



**福爱斯电子有限公司**  
VOICE ELECTRONICS CO.,LTD.

Office Add:Haoyangguang B-302# No.968 Baizhang Road,Ningbo China

Factory add: Shishan Industrial Park Moushan Town Yuyao City China

Tel:86-0574-87471601 Fax:86-0574-87471603 P.C.315000

Http://www.nbvoice.com E-mail:sales@nbvoice.com



Specification for Siren with Strobe Light	Page	3/5
	Revision No.	1.0
Model No. : VSL-102-V12R	Drawing No.	VS20140227019

## 2. Scope

This specification is applied to the siren used for sounder in alarm systems, Please contact us when using this product for any other applications than described in the above.

## 3. General

- 2.1 Out-Diameter : 72x123 mm
- 2.2 Height : 35 mm
- 2.3 Weight : 130 ±10g
- 2.4 Operating Temperature range:  
-20~+60°C without loss of function
- 2.5 Store Temperature range:  
-30~+70°C without loss of function

## 4. Electrical and Acoustic Characteristics.

Test condition : 15 ~ 35 °C, 25% ~ 85% RH, 860~1060 mbar

No	Items	Specification
1	Power	15W
2	Rated Voltage	12V DC
3	Working Voltage	6-15V DC
4	Max Rated Current	150mA/12VDC
5	Piezo Frequency	2.3-4.3KHz
6	Case Material/Color	ABS/White
7	Lens Material/Color	Acrylic/Red
8	Wires Connection	Red +12VDC、Black GND
9	Strobe Source	LEDS
10	SPL	110dB at 1M
11	Sound	1Tone
12	Strobe Current	50mA(average)
13	Strobe Frequency	120-150 times/minute

# Specification for Siren with Strobe Light

Page

4/5

Revision No.

1.0

Model No. : VSL-102-V12R

Drawing No.

VS20140227019

## 5. Dimensions

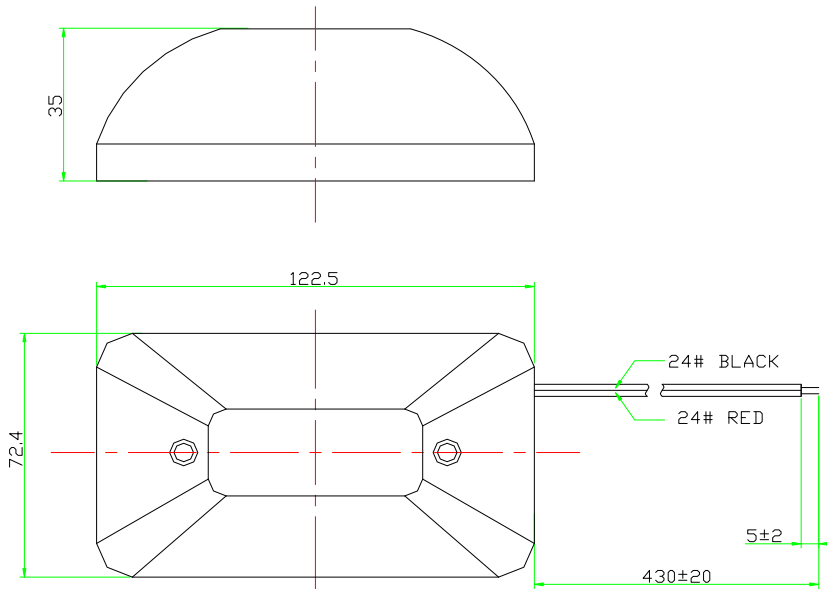

FIRST ANGLE PROJECTION

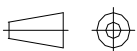

UNIT : mm

Tolerance :  $\pm 1.5$

Specification for Siren with Strobe Light	Page	5/5
	Revision No.	1.0
Model No. : VSL-102-V12R	Drawing No.	VS20140227019

## 6. Packing

Each minimum package unit of products shall be in a carton box and it shall marked with Part Number ,quantity .There shall be no mechanical damage products during tsansportation and/or in storage.

G.W./N.W.:14/13KGS  
Total:100 pcs per box  
Size:39X26X52CM