

Specification for Buzzer	Page	3/9
	Revision No.	1.1
	Drawing No.	OEM10797R
Model No. : KPI-G2301-K10797		

1. 范围 Scope

This product specification is applied to the piezoelectric sounder in alarm systems. Please contact us when using this product for any other applications than described in the above.

本规格书适用于压电式蜂鸣器，通常它用在系统中做报警或提示的蜂鸣器用，如果将该产品用于其它领域，请与我们联系。

2. 概要 General

2.1 Out-Diameter : Ø23mm

外径: Ø23 mm

2.2 Height : 9.8mm

高度: 9.8 mm

2.3 Weight : 2.5 gr.

重量: 2.5克

2.4 Case Material/Color : PC/Black

壳体材质/颜色: PC/黑色

3. 额定极限条件 Maximum Rating

	项目 Item	规格 Specification
3.1	输入电压 Maximum input Voltage	3~16V
3.2	工作温度范围 Operating Temperature Range	-40 ~ +85°C
3.3	储存温度范围 Storage Temperature Range	-40 ~ +85°C

Specification for Buzzer	Page	4/9
	Revision No.	1.1
	Drawing No.	OEM10797R
Model No. : KPI-G2301-Q10797		

4. 电性能 Electrical Characteristics

	项目 Item	规格 Specification
4.1	声压 Sound Pressure Level	≥90dB at 12VDC/30cm
4.2	频率 Resonant Frequency	3.8±0.5KHz
4.3	音调 Tone Nature	Continuous
4.4	电流 Max.Rated Current	≤30mA at 12VDC

测试条件参见下项

Refer to next item for measuring method.

5. 测试方法 Measuring Method

5.1 声压测试线路 S.P.L. Measuring Circuit

输入信号:12VDC
Input Signal:12VDC

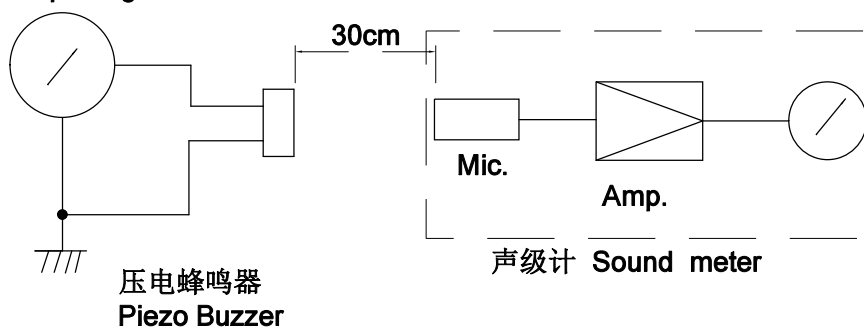

声级计: ND10 或等同品

Sound meter: ND10 or equivalent

稳压电源: DF1730SL2A或等同品

DC Power Supply: DF1730SL2A or equivalent

5.2 测试环境 Measuring Condition

温度+25±3℃, 湿度60±10%R.H.标准测试状态,在没有疑问的场合,可以在温度+5~+35℃,湿度45~85%R.H.的范围内测试.

Part shall be measured under a condition (Temperature :+5 to +35℃,Humidity :45 to 85%R.H.)unless the standard condition (Temperature :+25±3℃,Humidity :60±10%R.H.) is regulated measure.

Specification for Buzzer	Page	5/9
	Revision No.	1.1
	Drawing No.	OEM10797R

Model No. : KPI-G2301-Q10797

6. 机械性能 Physical Characteristics

	实验项目 Item	实验条件 Test Condition	实验后规格 Specification
6.1	耐冲击性 Shock	峰值加速度 490m/s^2 , 半正弦波, XYZ三个方向各3次冲击实验后, 测试声响器. Sounder shall be measured after being applied shock(490m/s^2) for each three mutually perpendicular directions to each of 3 times by half sine wave.	符合表1的要求 The measured value shall meet Table 1.
6.2	耐振动性 Vibration Resistant	振动频率 10~55 Hz, 1.5mm 全振幅, XYZ三个方向各2小时试验后, 测试声响器. Sounder shall be measured after being applied vibration of amplitude of 1.5mm with 10 to 55Hz band of vibration frequency to each of 3 perpendicular directions for 2 hours.	
6.3	耐焊接性 Soldering Heat Resistance	将声响器的插针插入(插至距声响器壳体1.5mm处为止) $350 \pm 5^\circ\text{C}$ 的焊锡槽 3 ± 0.5 秒, 然后在常温中放置4小时后, 测试声响器. Lead terminal are immersed up to 1.5mm from sounder's body in solder bath of $350 \pm 5^\circ\text{C}$ for 3 ± 0.5 seconds, and then sounder shall be measured after being placed in natural condition for 4 hours.	
6.4	跌落 Dropping	75cm高度/2回自然落到亚麻布垫上. Dropped from 75cm high to linen with 2 times.	
6.5	可焊性 Solderability	先将声响器的插针浸入松香液5秒钟, 然后浸入 $+260 \pm 5^\circ\text{C}$ 熔融的锡槽中 3 ± 0.5 秒. Lead terminals are immersed in rosin for 5 seconds and then immersed in solder bath of $+260 \pm 5^\circ\text{C}$ for 3 ± 0.5 seconds.	
6.6	插针强度 Terminal Strength Pulling	分别在每个插针的轴向施加9.8牛顿的静荷重10秒. The force 10 seconds of 9.8N is applied to each terminal in axial direction.	

Specification for Buzzer Model No. : KPI-G2301-Q10797	Page	6/9
	Revision No.	1.1
	Drawing No.	OEM10797R

7. 环境性能 Environmental Characteristics

	实验项目 Item	实验条件 Test Condition	实验后规格 Specification
7.1	高温放置 Dry Heat Test (Storage)	<p>放置于温度$+85\pm 2^{\circ}\text{C}$的烘箱内240小时, 然后取出, 在常温下放置4小时后, 测试声响器。</p> <p>After being placed in a chamber with $+85\pm 2^{\circ}\text{C}$ for 240 hours and then being placed in natural condition for 4 hours, sounder shall be measured.</p>	符合表1的要求 The measured value shall meet Table 1.
7.2	低温放置 Cold Heat Test (Storage)	<p>放置于温度$-40\pm 2^{\circ}\text{C}$的制冷箱内240小时, 然后取出, 在常温下放置4小时后, 测试声响器。</p> <p>After being placed in a chamber with $-40\pm 2^{\circ}\text{C}$ for 240 hours and then being placed in natural condition for 4 hours, sounder shall be measured.</p>	
7.3	耐湿性 Humidity	<p>放置于 90%~95% R.H., 温度$+60\pm 2^{\circ}\text{C}$的环境试验箱内240小时, 然后取出, 在常温下放置4小时后, 测试声响器。</p> <p>After being placed in a chamber with 90 to 95%R.H. at $+60\pm 2^{\circ}\text{C}$ for 240 hours and then being placed in natural condition for 4 hours, sounder shall be measured.</p>	
7.4	温度循环 Temperature Cycle	<p>先放置于温度$-40\pm 2^{\circ}\text{C}$的制冷箱内30分钟, 然后放置于室温($+20^{\circ}\text{C}$)15分钟后, 放置于$+85\pm 2^{\circ}\text{C}$的烘箱内30分钟, 再放置于室温($+20^{\circ}\text{C}$)15分钟。</p> <p>经过以上循环5次, 在常温下放置4小时后, 测试声响器。</p> <p>After being placed in a chamber at $-40\pm 2^{\circ}\text{C}$ for 30 minutes, sounder shall be placed at room temperature ($+20^{\circ}\text{C}$). After 15 minutes at this temperature, sounder shall be placed in a chamber at $+85\pm 2^{\circ}\text{C}$. After 30 minutes at this temperature, sounder shall be returned to room temperature ($+20^{\circ}\text{C}$) for 15 minutes.</p> <p>After 5 above cycles, sounder shall be measured after being placed in natural condition for 4 hours.</p>	

表 1 Table 1

项 目 Item	试验后变化量 Specification after test
声压级 Sound Pressure Level	初始值 $\pm 10\text{dB}$ Initial Value $\pm 10\text{dB}$

Specification for Buzzer	Page	7/9
	Revision No.	1.1
	Drawing No.	OEM10797R
Model No. : KPI-G2301-Q10797		

8. Dimensions

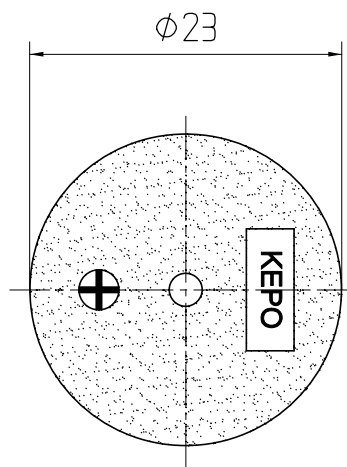
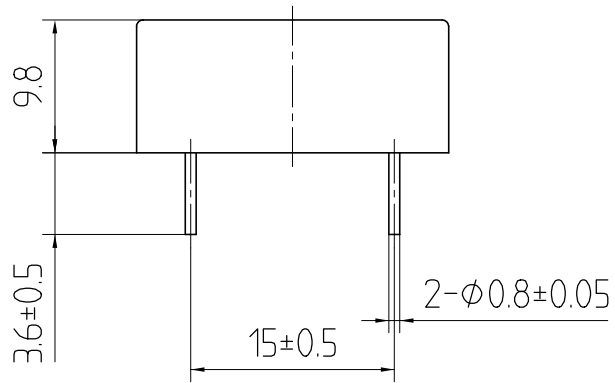

FIRST ANGLE PROJECTION



UNIT : mm
Tolerance : ±0.5