

规格书编号

SPEC NO :

# 产品规格书

# SPECIFICATION

CUSTOMER 客户: \_\_\_\_\_  
PRODUCT 产品: \_\_\_\_\_ SAW RESONATOR  
MODEL NO 型号: \_\_\_\_\_ HDR433.385MS6  
PREPARED 编制: \_\_\_\_\_ CHECKED 审核: \_\_\_\_\_  
APPROVED 批准: \_\_\_\_\_ D A T E 日期: \_\_\_\_\_ 2012-7-18

客户确认 CUSTOMER RECEIVED:		
审核 CHECKED	批准 APPROVED	日期 DATE

无锡市好达电子有限公司  
Shoulder Electronics Limited

## 更改历史记录 History Record

更改日期 Date	规格书编号 Spec. No.	产品型号 Part No.	客户产品型号 Customer No.	更改内容描述 Modify Content	备注 Remark

## 1. Scope

This specification shall cover the characteristics of 1-port SAW resonator with R433.385M used for remote-control security.

## 2. Electrical Specification

### 2.1 Maximum Rating

DC Voltage VDC	10V
AC Voltage Vpp	10V 50Hz/60Hz
Operation temperature	-40°C to +85°C
Storage temperature	-45°C to +85°C
Source Power	0dBm

### 2.2 Electronic Characteristics

Item	Unites	Minimum	Typical	Maximum	
Center Frequency	MHz	433.310	433.385	433.460	
Insertion Loss	dB		1.25	2.0	
Quality Factor	Unload Q	12000	14000		
	50Ω Loaded Q	1000	2000		
Temperature	Turnover Temperature	°C	10	25	40
Stability	Freq.temp.Coefficient	ppm/°C	0.032		
Frequency Aging		ppm/yr	<±10		
DC. Insulation Resistance	MΩ	1.0			
Transducer Static Capacitance C0	pF		1.5		

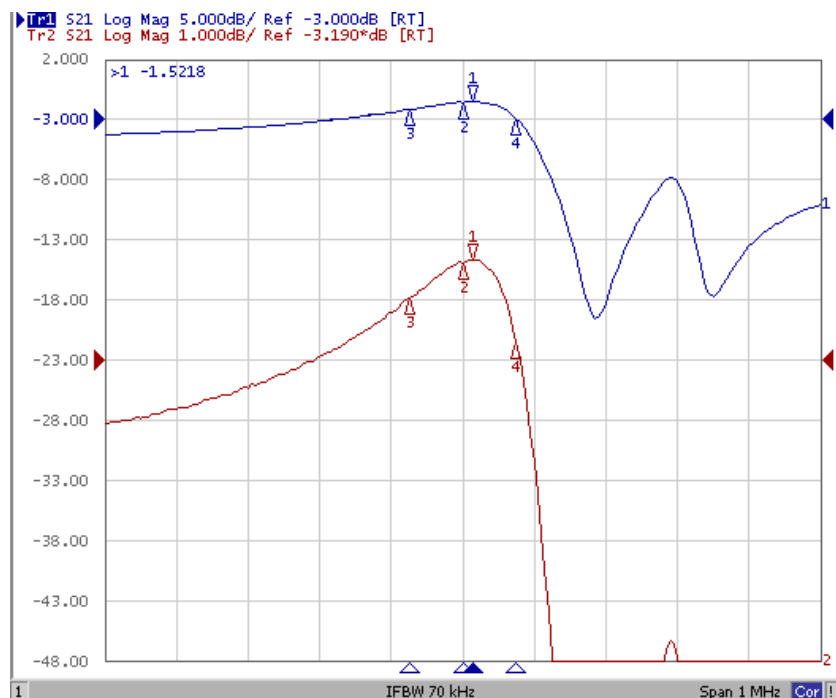

2.3 Equivalent LC Model

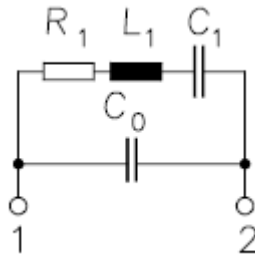

3. Test Circuit

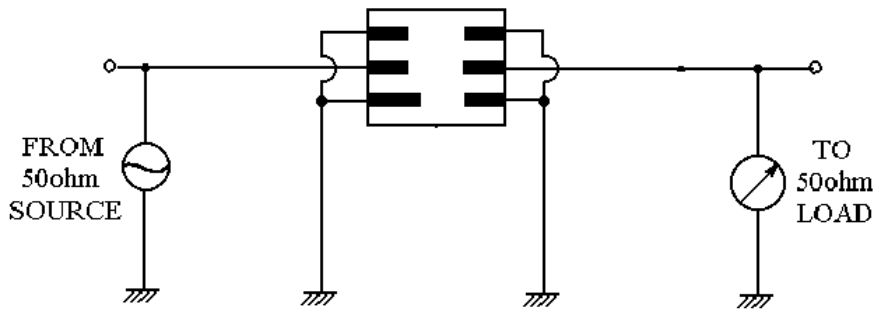

4. Dimension

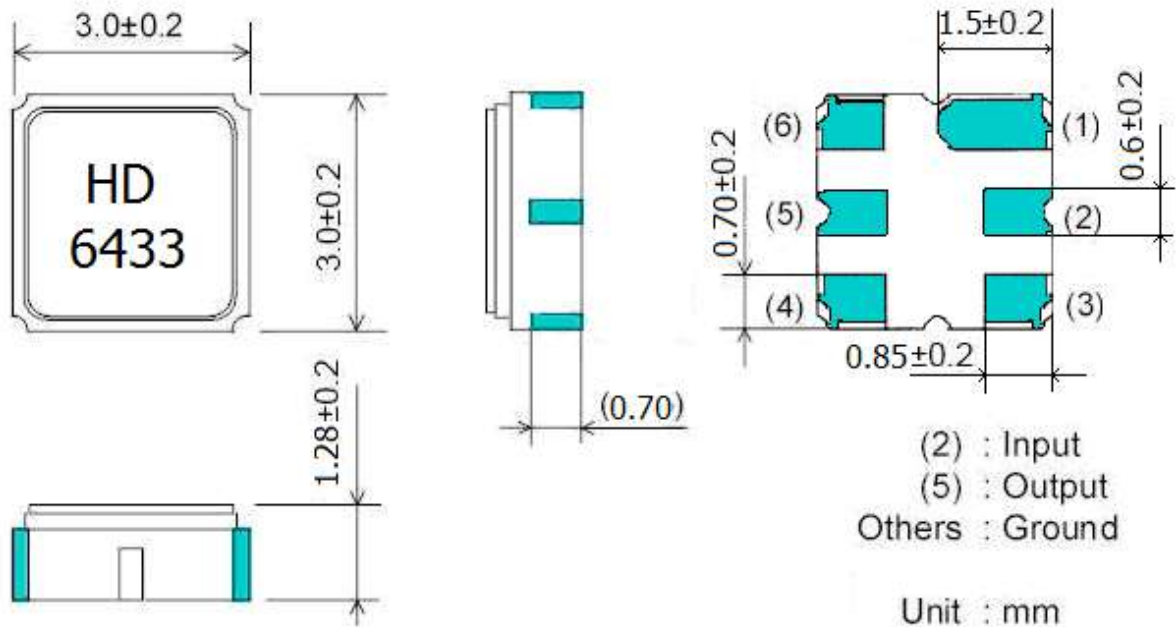

## 5. Environment Characteristic

### 5-1 Thermal Shock:

The components shall remain within the electrical specifications after being kept at the condition of heat cycle conditions:  $T_A = -40^{\circ}\text{C} \pm 3^{\circ}\text{C}$ ,  $T_B = 85^{\circ}\text{C} \pm 2^{\circ}\text{C}$ ,  $t_1 = t_2 = 30\text{min}$ , switch time  $\leq 3\text{min}$  & cycle time : 100 times, recovery time:  $2\text{h} \pm 0.5\text{h}$ .

### 5-2 Resistance to solder heat

Submerge the device terminals into the solder bath at  $260^{\circ}\text{C} \pm 5^{\circ}\text{C}$  for  $10 \pm 1$  sec. Then release the device into the room conditions for 4 hours. It shall meet the specifications in 2.2.

### 5-3 Solder ability

Submerge the device terminals into the solder bath at  $245^{\circ}\text{C} \pm 5^{\circ}\text{C}$  for 5s, More than 95% area of the soldering pad must be covered with new solder. It shall meet the specifications in 2.2

### 5-4 The Temperature Storage:

5.3.1 High Temperature Storage: The components shall remain within the electrical specifications after being kept at the  $85^{\circ}\text{C} \pm 2^{\circ}\text{C}$  for  $96\text{h} \pm 4\text{h}$ , recovery time :  $2\text{h} \pm 0.5\text{h}$ .

5.3.2 Low Temperature Storage: The components shall remain within the electrical specifications after being kept at the  $-40^{\circ}\text{C} \pm 3^{\circ}\text{C}$  for  $96\text{h} \pm 4\text{h}$ , recovery time :  $2\text{h} \pm 0.5\text{h}$ .

### 5-5 Humidity test:

The components shall remain within the electrical specifications after being kept at the condition of ambient temperature  $60^{\circ}\text{C} \pm 2^{\circ}\text{C}$ , and 90~96% RH for  $96\text{h} \pm 4\text{h}$ .

### 5-6 Mechanical shock

Drop the device randomly onto the concrete floor from the height of 1m for 3 times. The resonator shall fulfill the specifications in 2.2.

### 5-7 Vibration

Subject the device to the vibration for 2 hour each in X, Y and Z axes with the amplitude of 1.5 mm at 10 to 55 Hz. The resonator shall fulfill the specifications in 2.2.

## 6. Remark

### 6.1 Static voltage

Static voltage between signal load & ground may cause deterioration & destruction of the component. Please avoid static voltage.

### 6.2 Ultrasonic cleaning

Ultrasonic vibration may cause deterioration & destruction of the component. Please avoid ultrasonic cleaning

6.3 Soldering

Only leads of component may be soldered. Please avoid soldering another part of component.

**7. Packing**

7.1 Dimensions

- (1) Carrier Tape: Figure 1
- (2) Reel: Figure 2
- (3) The product shall be packed properly not to be damaged during transportation and storage.

7.2 Reeling Quantity

- 1000 pcs/reel 7"
- 3000 pcs/reel 13"

7.3 Taping Structure

- (1) The tape shall be wound around the reel in the direction shown below.

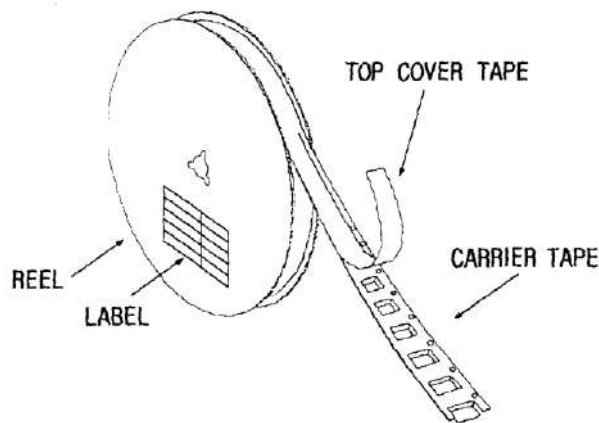

- (2) Label

Device Name	
User Product Name	
Quantity	
Lot No.	

- (3) Leader part and vacant position specifications.

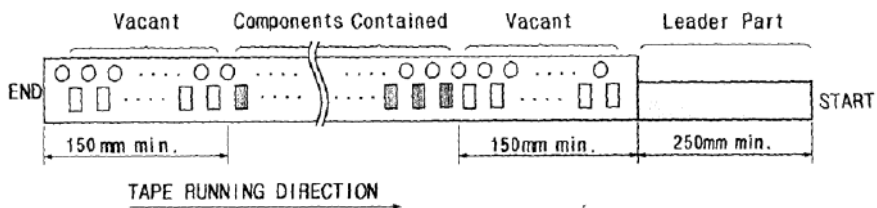

## 8. Tape Specifications

8.1 Tensile Strength of Carrier Tape: 4.4N/mm width

8.2 Top Cover Tape Adhesion (See the below figure)

- (1) pull off angle: 0~15°
- (2) speed: 300mm/min.
- (3) force: 20~70g

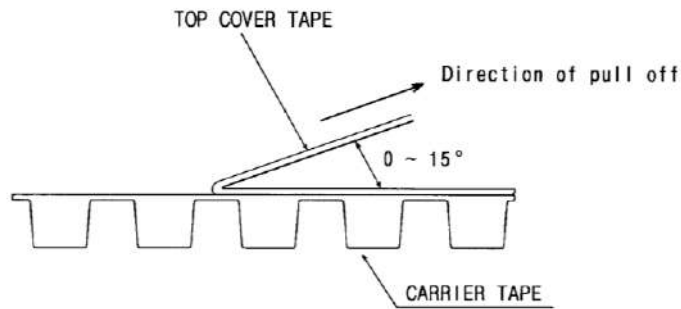

[Figure 1] Carrier Tape Dimensions

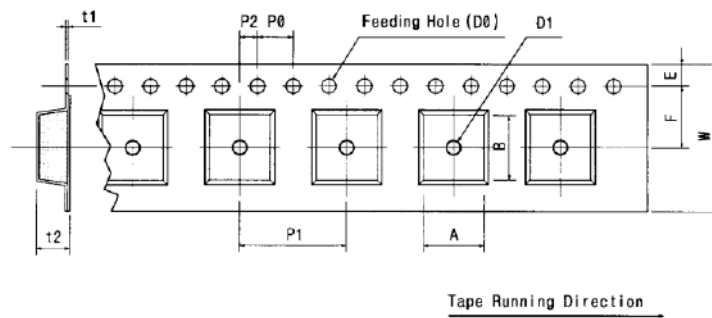

[Unit: mm]

W	F	E	P0	P1	P2	D0	D1	t1	t2	A	B
12.0	5.5	1.75	4.0	4.0	2.0	Ø1.5	Ø1.0	0.3	1.25	3.3±	3.3±
±0.3	±0.05	±0.1	±0.1	±0.1	±0.05	±0.1	±0.25	±0.05	±0.1	0.1	0.1

[Figure 2] Reel Dimensions

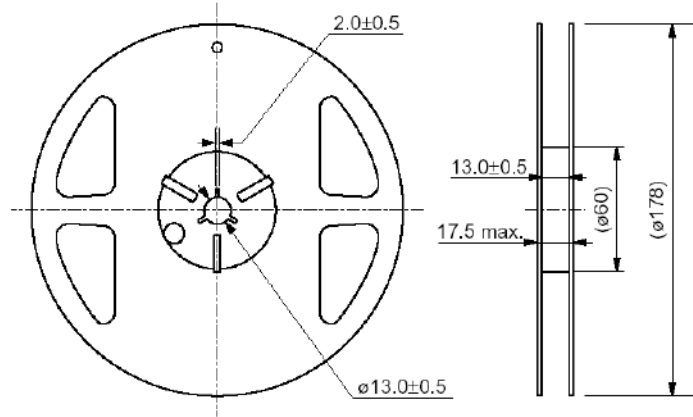

$\phi 178$  Reel Dimension

(in mm)

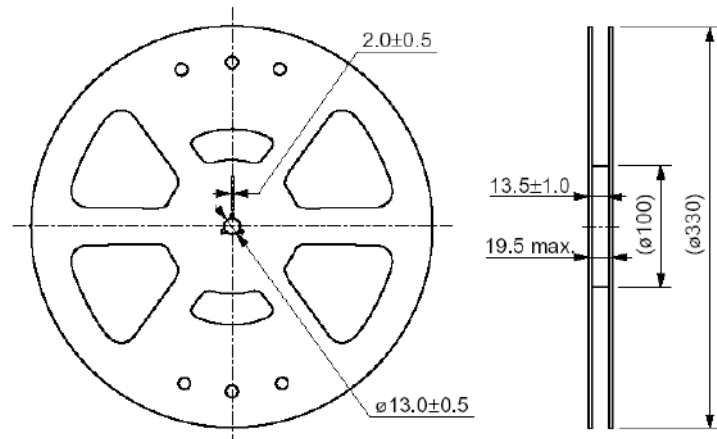

$\phi 330$  Reel Dimension

(in mm)