

规格书编号

SPEC NO :

产品规格书

SPECIFICATION

CUSTOMER 客户: _____
PRODUCT 产品: SAW FILTER
MODEL NO 型号: HDIF389B1M SIP5K
PREPARED 编制: _____ CHECKED 审核: _____
APPROVED 批准: _____ DATE 日期: 2004-8-15

客户确认 CUSTOMER RECEIVED:		
审核 CHECKED	批准 APPROVED	日期 DATE

无锡市好达电子有限公司
Shoulder Electronics Limited

更改历史记录 History Record

更改日期 Date	规格书编号 Spec. No.	产品型号 Part No.	客户产品型号 Customer No.	更改内容描述 Modify Content	备注 Remark

1.SCOPE

SHOULDER's SAW filter series have broad line up products meeting all broadcast standard including NTSC,PAL and SECAM systems. These filters are composed of two interdigital transducers on a single-crystal, piezoelectrical chip. they are used in electronic equipments such as TV and so on.

2.Construction

2.1 Dimension and materials

Manufacturer's name : SHOULDER ELECTRONICS Co. LTD(CHINA)

Type : IF389B1M

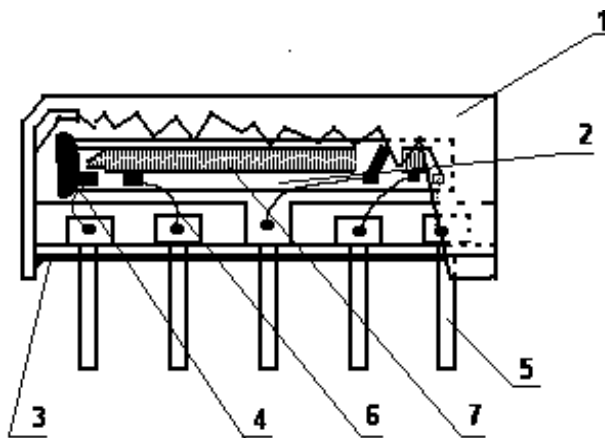
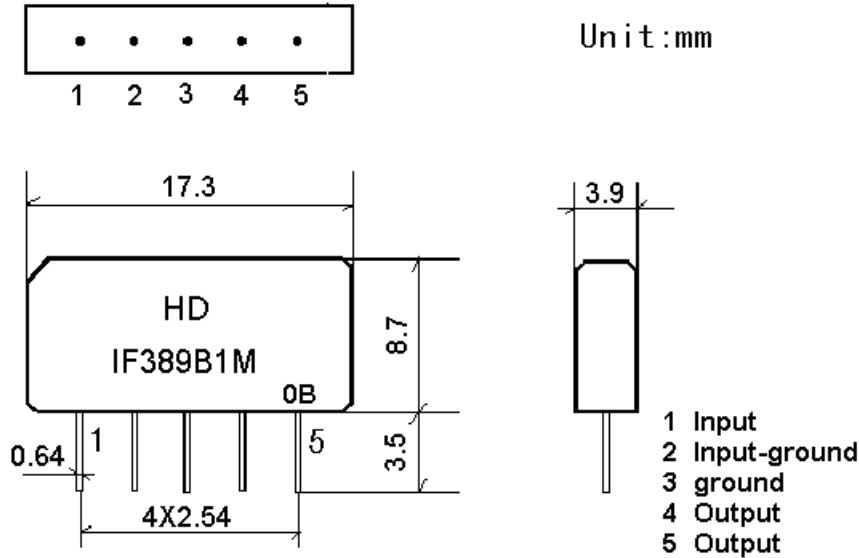

Components	Materials
1.Outer casing	PPS
2.Substrate	Lithium niobate
3.Base	Epoxy resin
4.Absorber	Epoxy resin
5.Lead	Cu alloy+Au plate
6.Bonding wire	AlSi alloy
7.Electrode	Al

2.2. Circuit construction, measurement circuit

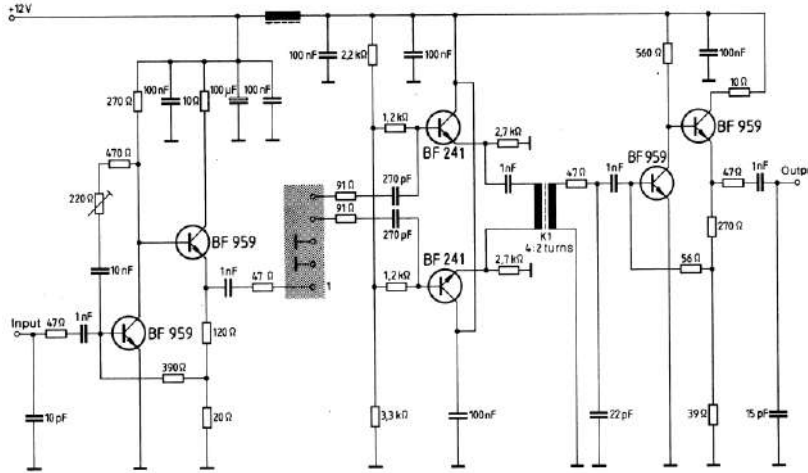

Test circuit for SIP-5 filter
Input impedance of the symmetrical post-amplifier: 2 kΩ in parallel with 3 pF

3.Characteristics

Items	Conditions	Specifications
Standard atmospheric conditions	Unless otherwise specified , the standard rang of atmospheric conditions for making measurements and tests is as follows; Ambient temperature : 15°C to 35°C Relative humidity : 25% to 85% Air pressure : 86kPa to 106kPa	There shall be no damage.
Operating temperature rang	Operating temperature rang is the rang of ambient temperatures in which the filter can be operated continuously. -10°C ~ +60°C	
Storage temperature rang	Storage temperature rang is the rang of ambient temperatures at which the filter can be stored without damage. Conditions are as specified elsewhere in these specifications. -40°C ~ +70°C	
Reference temperature	+25°C	

3.1 Maximum Rating

DC voltage	VDC	12	V	Between any terminals
AC voltage	Vpp	10	V	Between any terminals

3.2 Electrical Characteristics

Source impedance

 $Z_s=50\ \Omega$

Load impedance

 $Z_L=2k\ \Omega //3pF$
 $T_A=25^\circ C$

Items	Freq	Min	typ	max	
Insertion attenuation Reference level	37.4MHz	16.1	17.6	19.1	dB
	38.9MHz	4.2	5.7	7.2	dB
Relative attenuation	34.47MHz	2.3	3.8	5.3	dB
	32.4MHz	18.8	20.3	-	dB
	33.4MHz	19.4	20.9	-	dB
	30.9MHz	44.0	58		dB
	40.4MHz	42.0	52		dB
	41.4MHz	42.0	50		dB
Sidelobe	25.00~30.90MHz	35.0	45		dB
	40.40~45.00MHz	35.0	42		dB
Temperature coefficient		-72			Ppm/k

3.3 Environmental Performance Characteristics

Item	Condition	Specifications
High temperature	The specimen shall be store at a temperature of $80\pm 2^\circ C$ for $96\pm 4h$. Then it shall be subjected to standard atmospheric conditions for 1h, after which measurement shall be made within 1h.	Mechanical characteristics and specifications in electrical characteristics shall be satisfied. There shall be no excessive change in appearance.
Low temperature	The specimen shall be store at a temperature of $-20\pm 3^\circ C$ for $96\pm 4h$. Then it shall be subjected to standard atmospheric conditions for 1h, after which measurement shall be made within 1h.	
Humidity	The specimen shall be store at a temperature of $40\pm 2^\circ C$ with relative humidity of 90% to 96% for $96\pm 4h$. Then it shall be subjected to standard atmospheric conditions for 1h, after which measurement shall be made within 1h.	
Thermal shock	The specimen shall be subjected to 8 continuous cycles each as shown below. Then it shall be subjected to standard atmospheric conditions for 1h, after which measurement shall be made within 1h.	

	Temperature	Duration	
	+25 °C=>-40 °C	0.5h	
	-40 °C	4h	
	-40 °C=>+85 °C	2h	
	+85 °C	4h	
	+85 °C=>+25 °C	0.5h	
	+25 °C	1h	
Resistance to Soldering heat	Reflow soldering method Peak: 255 ±5 °C, 220 ±5 °C, 40s At electrode temperature of the specimen.		
	<p>The graph shows the temperature profile for reflow soldering. The y-axis is 'Soldering temperature' from 0 to 300. The x-axis shows time intervals: '1 to 2 min.' for pre-heating, '10s' for soldering, and '2 min. or more' for slow cooling. The temperature rises to 150°C during pre-heating, then to 255°C during soldering, and finally cools down to room temperature.</p>		
	The specimen shall be passed through the reflow furnace with the condition shown in the above profile for 1 time. The specimen shall be stored at standard atmospheric conditions for 1h, after which the measurement shall be made. Test board shall be 1.6 mm thick. Base material shall be glass fabric base epoxy resin.		
Solder ability	Immerse the pins melt solder at 260°C+5/-0°C for 5 sec.	More then 95% of total area of the pins should be covered with solder	

3.4 Mechanical Test

Items	Conditions	Specifications
Vibration	600-3300rpm amplitude 1.5mm 3 directions 2 H each	There shall be no damage.
Drop	On maple plate from 1 m high 3 times	
Lead pull	Pull with 1 kg force for 30 seconds	
Lead bend	90° bending with 500g weigh 2 times	

3.5 Voltage Discharge Test

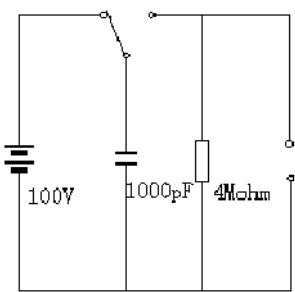
Item	Condition	Specifications
Surge	Between any two electrode 	There shall be no damage

3.6 Frequency response

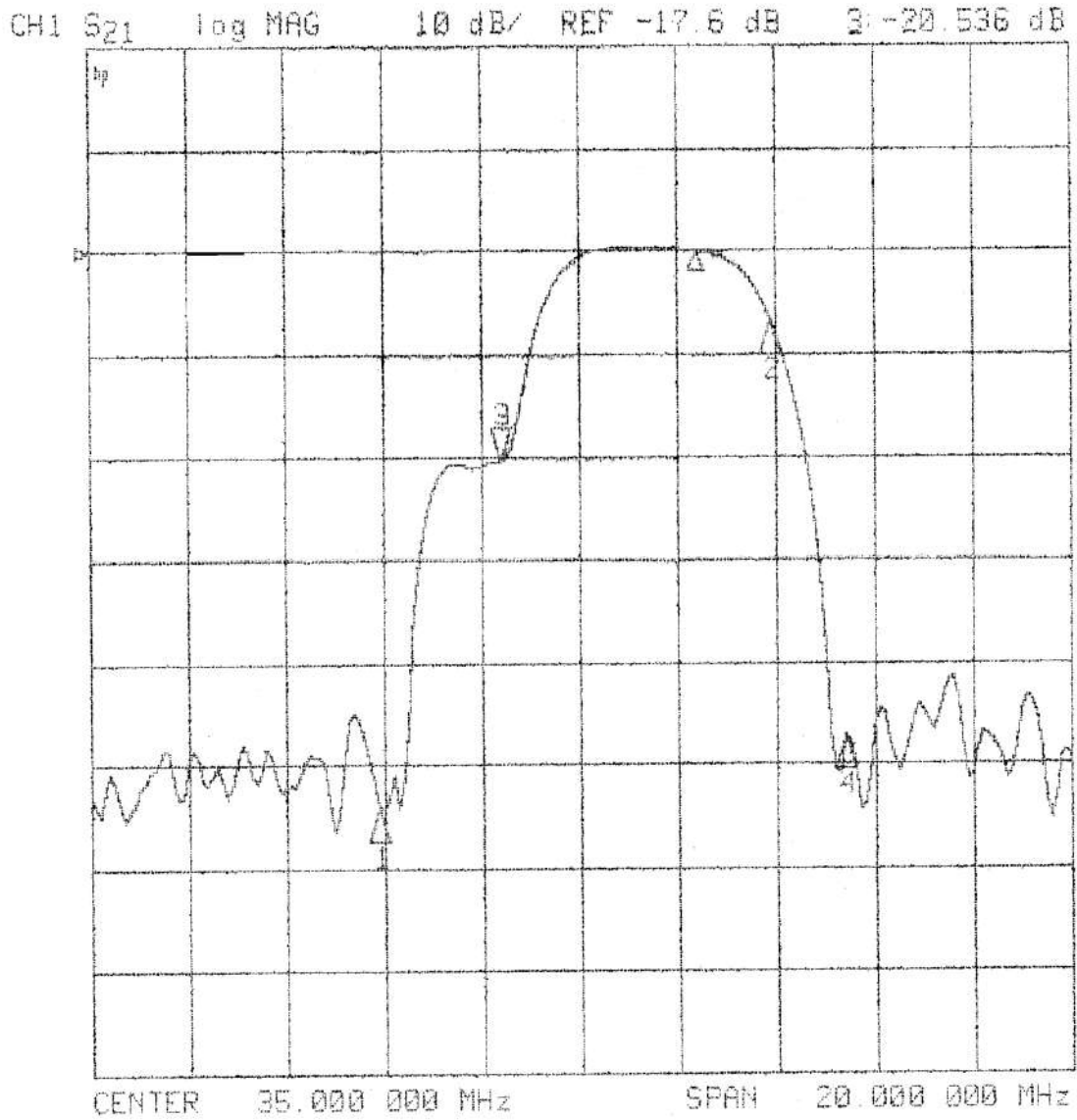

CH1 S21 delay 30 ns/ REF 1.17 ps 2: 17.228 ns
CH2 S21 log MAG 1 dB/ REF -17.6 dB 2: -6.6048 dB

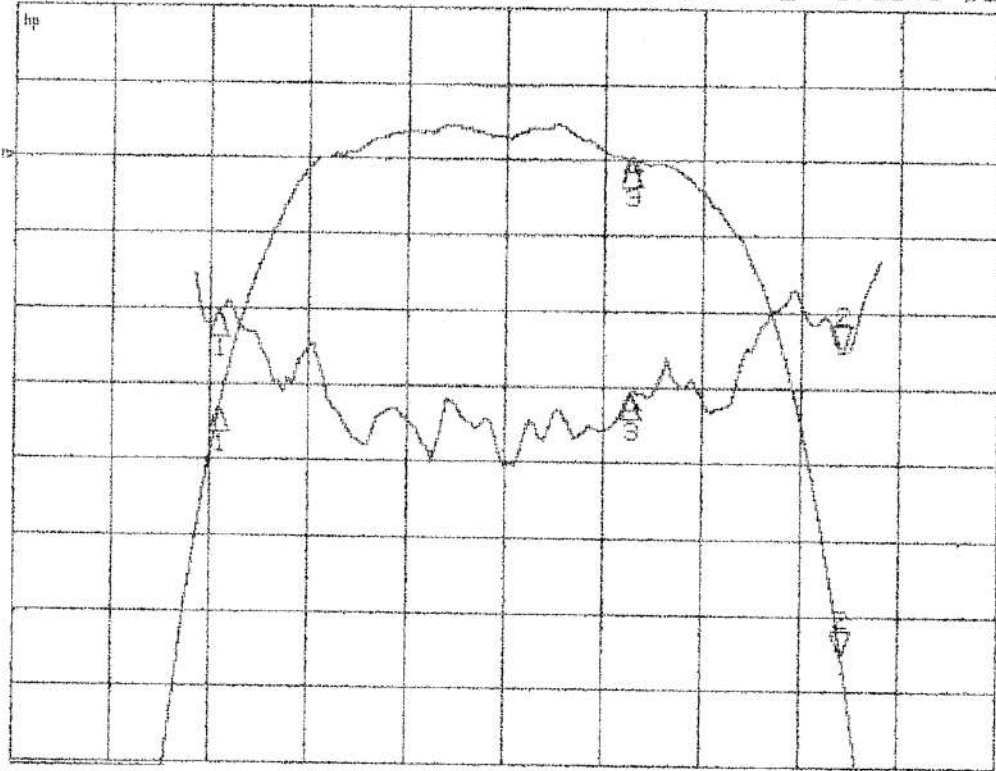

CENTER 36.500 000 MHz SPAN 7.000 000 MHz

CH1 S21 log MAG 10 dB/ REF -17.6 dB

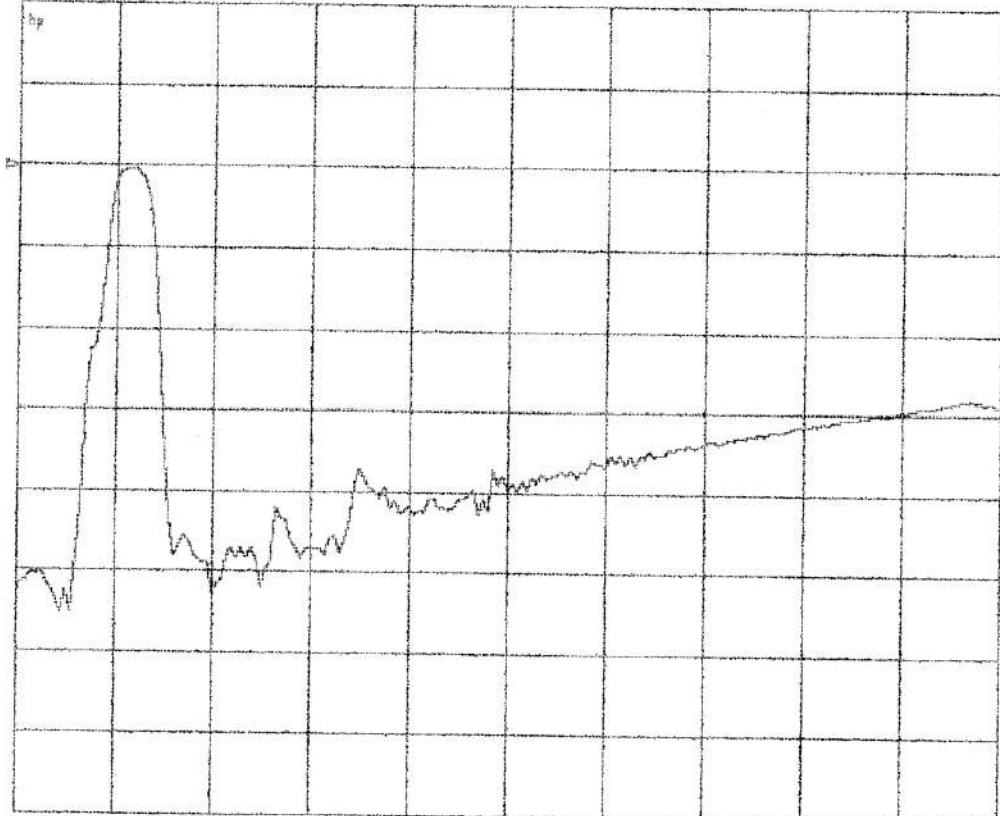

START 25.000 000 MHz STOP 125.000 000 MHz