





## 1. SCOPE

This specification shall cover the characteristics of SAW filter With F155M used for the page system.

## 2. ELECTRICAL SPECIFICATION

DC Voltage VDC	10V
AC Voltage Vpp	10V50Hz/60Hz
Operation temperature	-40°C to +85°C
Storage temperature	-45°C to +85°C
RF Power Dissipation	0dBm

### 2-1. Typical frequency response

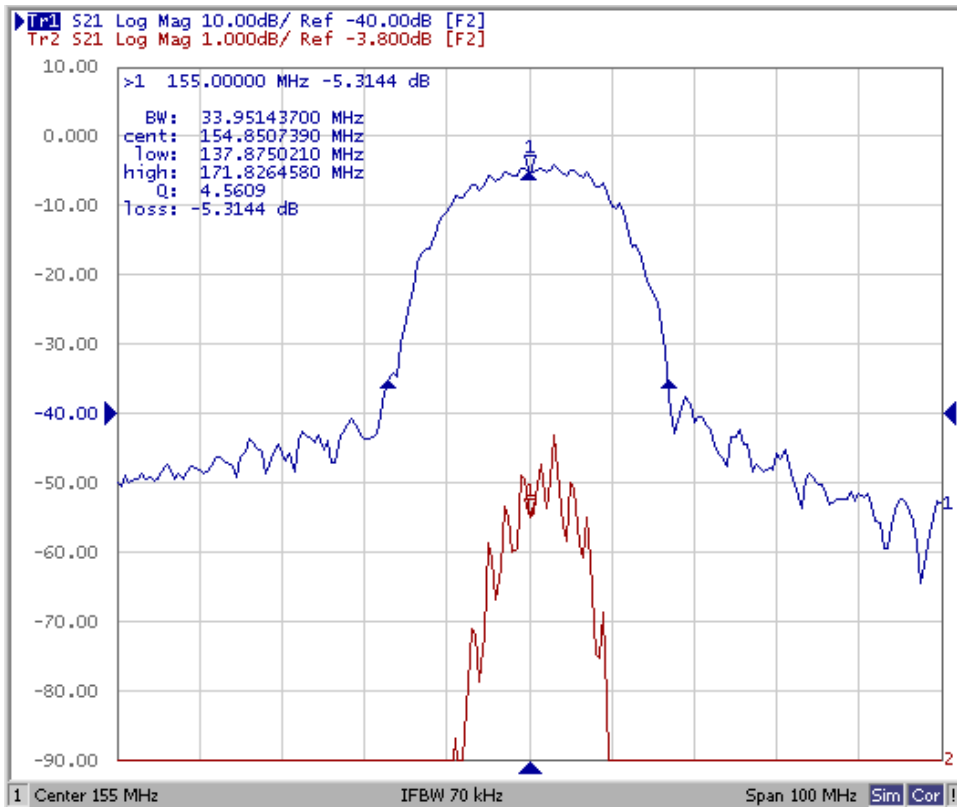

2-2Electrical characteristics

Part number	HDF155	Unit
Nominal center frequency (Fo)	155	MHz
Insertion Loss(Fo ± 4MHz)	6.5max	dB
Fo -100MHz to Fo -46.8MHz	50min	dB
Fo -46.8MHz to Fo -38.8MHz	50min	dB
Fo ± 38.8MHz to 2.5×Fo	42min	dB
Input/Output Impedance(Nominal)	210// -12.3	Ω /pF

**3. TEST CIRCUIT**

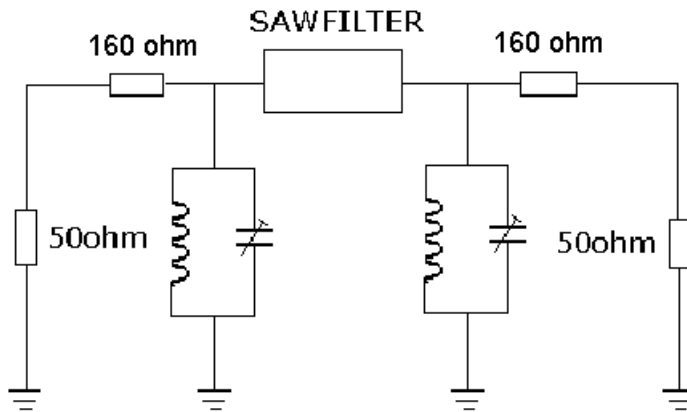

**4. DIMENSION**

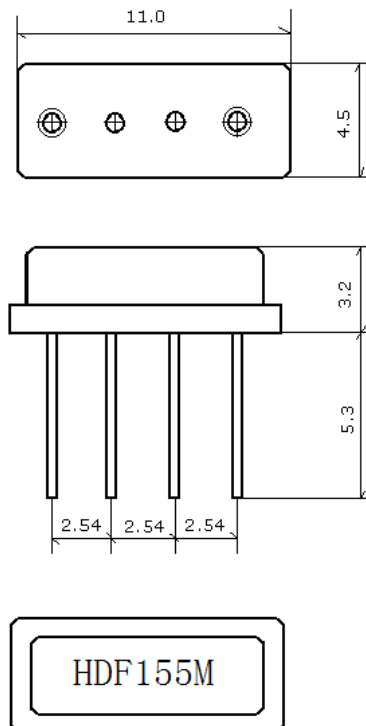

## 5. ENVIRONMENTAL CHARACTERISTICS

### 5-1 High temperature exposure

Subject the device to +85°C for 16 hours. Then release the filter into the room conditions for 24 hours prior to the measurement. It shall fulfill the specifications in 2-2.

### 5-2 Low temperature exposure

Subject the device to -40°C for 16 hours. Then release the device into the room conditions for 24 hours prior to the measurement. It shall fulfill the specifications in 2-2.

### 5-3 Temperature cycling

Subject the device to a low temperature of -40°C for 30 minutes. Following by a high temperature of +85°C for 30 Minutes. Then release the device into the room conditions for 24 hours prior to the measurement. It shall meet the specifications in 2-2.

### 5-4 Resistance to solder heat

Dip the device terminals no closer than 1.5mm into the solder bath at 260°C  $\pm$ 10°C for 10 $\pm$ 1 sec. Then release the device into the room conditions for 4 hours. The device shall meet the specifications in 2-2.

### 5-5 Solderability

Subject the device terminals into the solder bath at 245°C  $\pm$ 5°C for 5s, More than 95% area of the terminals must be covered with new solder. It shall meet the specifications in 2-2.

### 5-6 Mechanical shock

Drop the device randomly onto the concrete floor from the height of 1m 3 times. the device shall fulfill the specifications in 2-2.

### 5-7 Vibration

Subject the device to the vibration for 1 hour each in x,y and z axes with the amplitude of 1.5 mm at 10 to 55 Hz. The device shall fulfill the specifications in 2-2.

## 6. REMARK

### 6.1 Static voltage

Static voltage between signal load & ground may cause deterioration & destruction of the component. Please avoid static voltage.

### 6.2 Ultrasonic cleaning

Ultrasonic vibration may cause deterioration & destruction of the component. Please avoid ultrasonic cleaning

### 6.3 Soldering

Only leads of component may be soldered. Please avoid soldering another part of component.