

# AN5270

## 4.3 W × 1(8Ω) Power Amplifier with Volume Control and Tone Control

### ■ Overview

The AN5720 is an integrated circuit designed for 4.3 W(8 Ω) power amplifier with volume control and tone control.

### ■ Features

- DC volume control : 0 to 5 V
- DC tone control : 0 to 5 V
- 9-lead single-in-line plastic package with fin

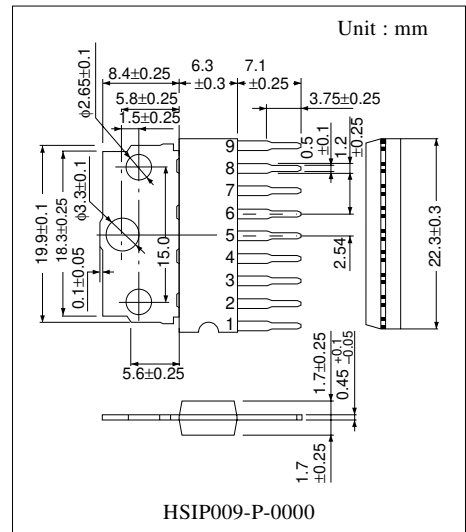

### ■ Block Diagram

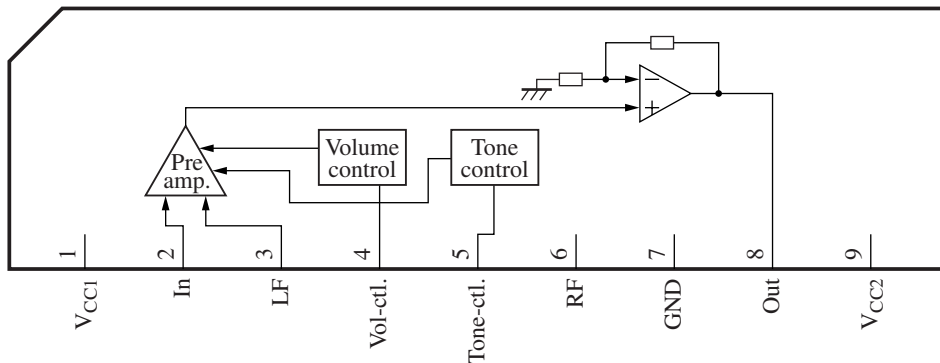

### ■ Pin Descriptions

Pin No.	Pin Name
1	V <sub>CC1</sub>
2	Sound input
3	Low frequency input
4	Volume control
5	Tone control
6	Ripple filter
7	Ground
8	Sound output
9	V <sub>CC2</sub>

Note) Pins 2 and 4 are weaker in protection against positive surge than the other pins.

It is necessary to pay attention during application use.

### ■ Absolute Maximum Ratings

Parameter	Symbol	Ratings	Unit
Supply voltage	$V_{CC1}(V_{1-7})$	14	V
	$V_{CC2}(V_{9-7})$	26	
Circuit voltage	$V_{2-7}$	0 to $V_{9-7}$	
	$V_{3-7}$	0 to $V_{9-7}$	
	$V_{4-7}$	0 to $V_{1-7}$	
	$V_{5-7}$	0 to $V_{1-7}$	
Supply current	$I_{CC1}$	15	mA
	$I_{CC2}$	2	A
Circuit current <sup>*3, 4</sup>	$I_8$	-1.7 to +1.7	$A_{PP}$
Power dissipation <sup>*2</sup>	$P_D$	1.6	W
Operating ambient temperature <sup>*1</sup>	$T_{opr}$	-20 to +70	°C
Storage temperature <sup>*1</sup>	$T_{stg}$	-55 to +150	°C

Note) Do not apply a current or voltage from the external to the terminals that are not described above.

\*1 :  $T_a = 25\text{ °C}$ , excluding parameters regarding ambient temperature and storage temperature.

\*2 :  $T_a = 70\text{ °C}$ , the IC is mounted on PCB, without external heat sink.

\*3 : For circuit currents, '+' denotes current flowing into the IC, and '-' denotes current flowing out of the IC.

\*4 : As the output Pin8 does not have over current protection circuit incorporated, therefore please take precaution **not** to short the output pin to either  $V_{CC}$  or GND.

### ■ Recommended Operating Range

Parameter	Symbol	Range	Unit
Operating supply voltage range	$V_{CC1}$	11 to 13	V
	$V_{CC2}$	15 to 24	

■ Electrical Characteristics at  $V_{CC1} = 12\text{ V}$ ,  $V_{CC2} = 18\text{ V}$ ,  $f = 1\text{ kHz}$ ,  $T_a = 25\text{ }^\circ\text{C}$ ,  $R_L = 8\text{ }\Omega$ , Vol. = max., Tone = max.

Parameter	Symbol	Conditions	Min	Typ	Max	Unit
Quiescent current 1	$I_{TOT1}$	No input signal Measure $V_{CC1}$ current	7	10	13	mA
Quiescent current 2	$I_{TOT2}$	No input signal Measure $V_{CC2}$ current	20	28	48	mA
Output DC bias	$V_{ODC}$	No input signal Measure Pin8 DC	7.2	8.3	9.4	V
Voltage gain	$G_V$	$V_O = 1\text{ V}_{rms}$ , $G_V = 20\text{ log}(V_O / V_{IN})$	28	30	32	dB
Total harmonic distortion	THD	$V_O = 1\text{ V}_{rms}$ , BPF : 400 Hz to 30 kHz	—	0.5	1.0	%
Max. output power	Pomax	THD = 10 %, $P_O = V_O^2 / R_L$	4.0	4.3	—	W
Max. output attenuation	Attmax	$V_O = 1.0\text{ V}_{rms}$ , Vol. = max. → min. Attmax = $20\text{ log} [V_{O(vol. = max.)} / V_{O(vol. = min.)}]$	—	-69	-66	dB
Tone variable range	$\Delta G_{TC}$	$f = 10\text{ kHz}$ , fix $V_{IN}$ where $V_{O(tone = max.)} = 1\text{ V}_{rms}$ Tone = max. → min. $\Delta G_{TC} = 20\text{ log} [V_{O(tone = max.)} / V_{O(tone = min.)}]$	18	20	—	dB

■ Application Circuit Example

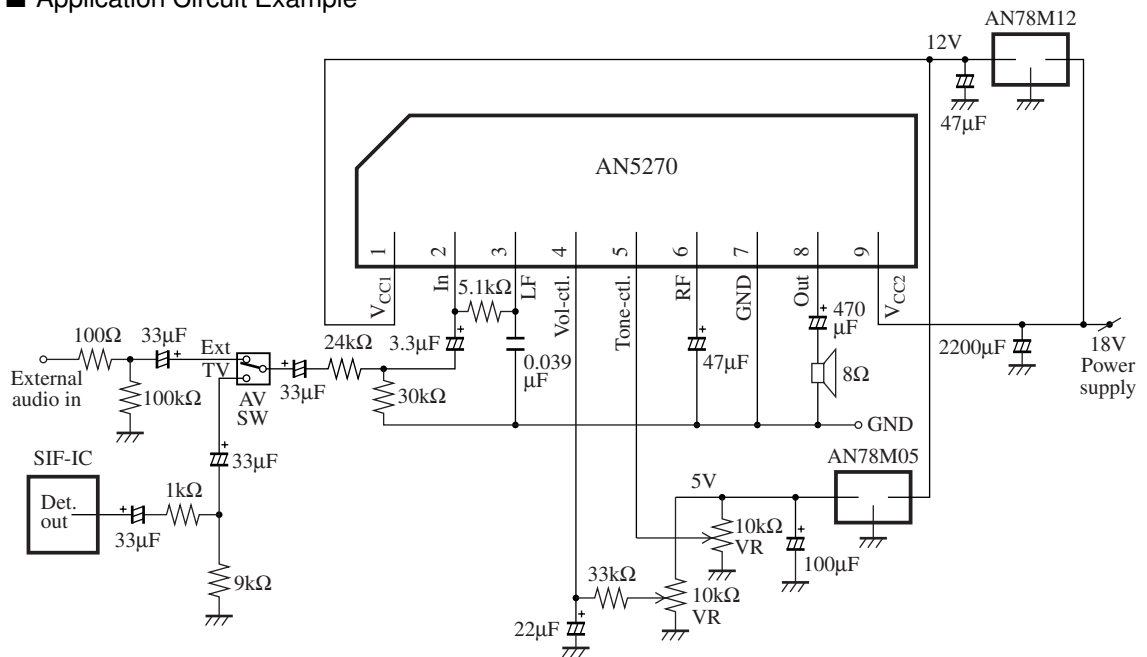

Note) Design considerations for shock noise prevention :

In the application of the IC, please adopt the above power supply configuration whenever possible.

Where this is not possible, then it is better to ensure that  $V_{CC1}$  should start up first before the onset of  $V_{CC2}$ , in order to prevent power-on shock noise. Similarly, please ensure that  $V_{CC2}$  declines faster than  $V_{CC1}$ , in order to prevent power-off shock noise.

■ Technical Information

• Characteristic curve chart

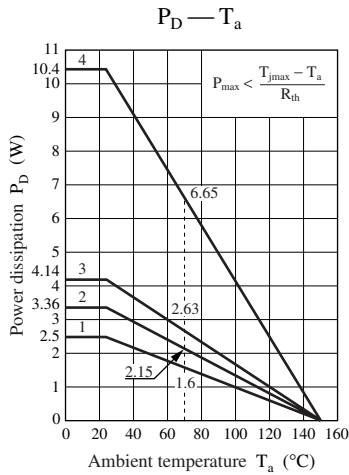

- 1 No heat sink
- 2 5.5 × 5.0 cm<sup>2</sup> Al board (t = 1 mm)
- 3 7.5 × 7.5 cm<sup>2</sup> Al board (t = 1 mm)
- 4 Infinity heat sink

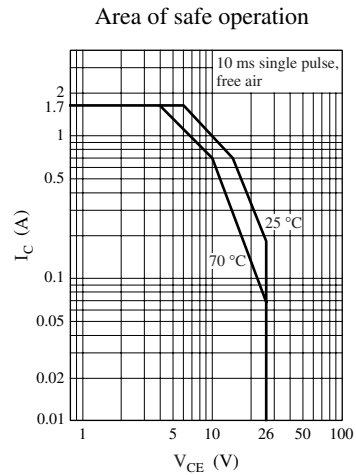

• Structure of pre-amp. stage

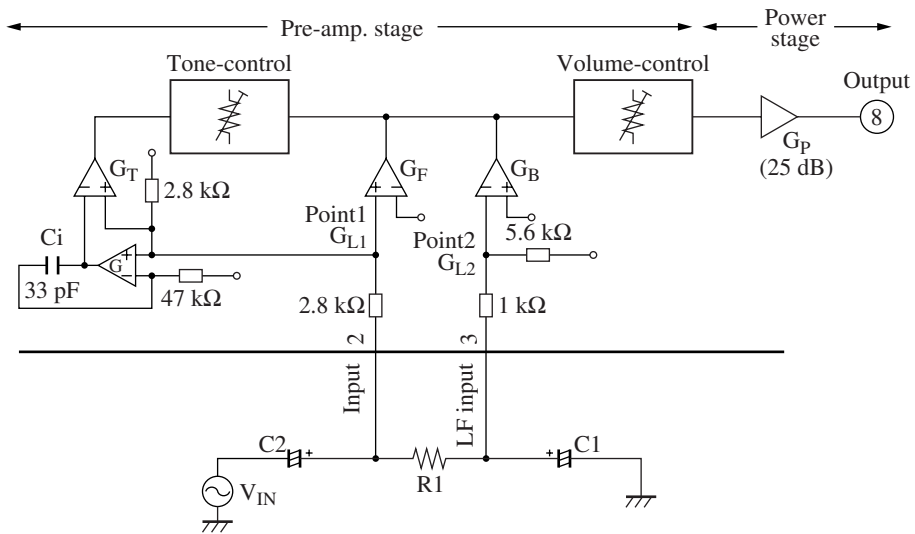

Fig. Simplified structure of AN5270 pre-amp. stage

Explanation of gain notations :

- $G_T$  : Gain of tone-amp. (treble-amp.)
- $G_F$  : Gain of flat-response amp.
- $G_B$  : Gain of bass-amp.
- $G_{L1}$  : Gain at point 1 with respect to  $V_{IN}$ .
- $G_{L2}$  : Gain at point 2 with respect to  $V_{IN}$ .
- $G_P$  : Gain of power stage.
- $G_{pre}$  : Gain of pre-amp. stage.

■ Technical Information (continued)

• Structure of pre-amp. stage (continued)

$G_F$  amp., the flat-amp., amplifies the signal equally for all frequencies in the range of 20 Hz to 70 kHz.

$G_T$  amp., the treble or tone-amp., has an internal LPF connected to its inverting input. The non-inverting input of  $G_T$  amp. is connected to the input signal. Thus, the output of  $G_T$  passes only the upper range of frequencies (cut-off frequency = 2.5 kHz).

$G_B$  amp., the bass-amp., amplifies the lower range of frequencies. Its cut-off frequency is determined by  $R1 \cdot C1$ . If LF pin is left open, then  $G_B$  amp. has no effect on the overall frequency response.

• Gain calculation

General formula for gain of pre-amp. is (when vol. = max., tone = max.) :

$$\vec{G}_{pre} = \vec{G}_{L1} \cdot (G_F + G_T) - \vec{G}_B \cdot \vec{G}_{L2}$$

By vector analysis as shown in fig. Vector diagram of  $G_{pre}$ ,

$$G_V [dB] = G_{pre} + G_P$$

$$G_V [dB] = 20 \log \sqrt{[G_{L1} \cdot (G_F + G_T) - G_B \cdot G_{L2} \cdot \cos\theta]^2 + (G_B \cdot G_{L2} \cdot \sin\theta)^2} + G_P$$

where  $G_{L1} = 0.5$

$$G_F = 1.3$$

$$G_B = 5.4$$

$$G_T = \begin{cases} 0 & \text{for (100 Hz)} \\ 1.3 & \text{for (1 kHz)} \\ 2.5 & \text{for (10 kHz)} \end{cases}$$

$$G_P = 25 \text{ dB}$$

$$G_B \approx \frac{Z3 \cdot 0.848}{Z3 + R1}$$

$$Z3 = \frac{6600}{\sqrt{1 + (2\pi f \cdot C1 \cdot 6600)^2}}$$

$$\theta = -\tan^{-1} (2\pi f \cdot C1 \cdot 6600)$$

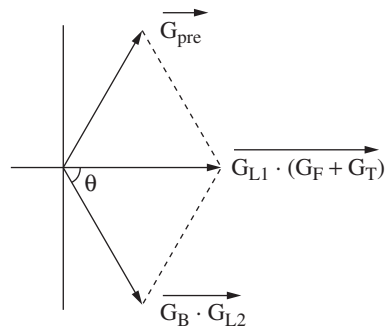

Fig. Vector diagram of  $G_{pre}$

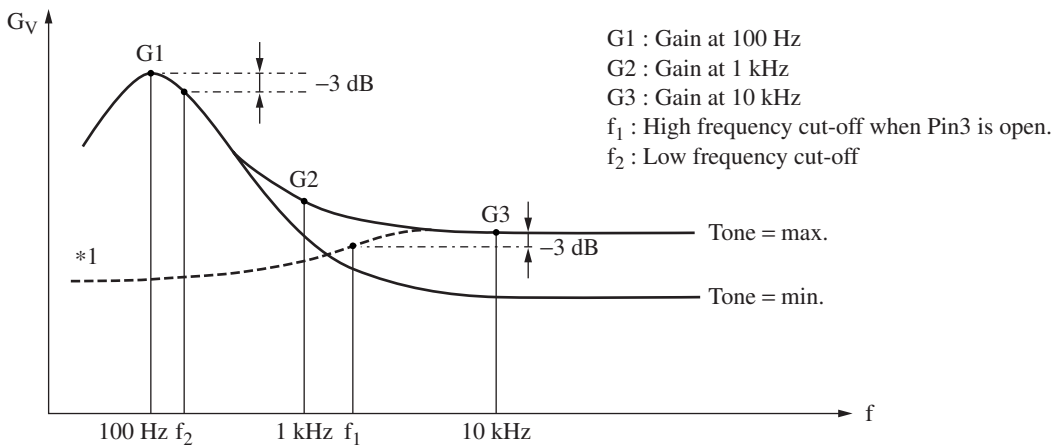

Fig. Frequency response of AN5270

Note) \*1 : This is the response if LF pin is open (i.e. R1 open).

## ■ Technical Information (continued)

### • Cut-off frequencies

$$f_1 = \frac{1}{2\pi \cdot G \cdot C_i \cdot R_i} = 2.5 \text{ kHz} \quad \text{where } G = 40 \text{ times, } C_i = 33 \text{ pF, } R_i = 47 \text{ k}\Omega$$

$$f_2 = \frac{1}{2\pi \cdot R_1 \cdot C_1} = 530 \text{ Hz} \quad \text{if } R_1 = 3 \text{ k}\Omega, C_2 = 0.1 \text{ }\mu\text{F}$$

### • Summary of frequency characteristics for typical values of R1 and C1

R1(Ω)	C1(F)	Actual Gain(dB)*			f <sub>2</sub> (Hz)	ΔG <sub>TC</sub> (dB)
		G1(100 Hz)	G2(1 kHz)	G3(10 kHz)		
2.2 k	0.039 μ	35.0	34.0	31.0	1.8 k	10.0
5.1k	0.039 μ	31.0	31.0	31.0	800	21.0
10 k	0.039 μ	26.0	27.5	30.0	408	21.0
20 k	0.039 μ	17.5	25.0	30.0	204	18.0
∞	—	24.0	26.0	30.0	—	14.0
1 k	0.1 μ	36.0	35.0	30.0	1.6 k	10.0
2.2 k	0.1 μ	34.0	32.0	30.0	723	19.0
3 k	0.1 μ	33.0	31.0	30.0	530	21.0
5.1 k	0.1 μ	31.0	29.0	30.0	312	19.0
10 k	0.1 μ	26.0	27.0	30.0	159	17.0
20 k	0.1 μ	18.0	26.0	30.0	80	16.0

Note) \* : Tone = max.

Table. Tabulated summary of frequency characteristics of AN5270.

### • Volume control

The volume control range is 0 to 5 V. This range is adopted so as to simplify the pull-up of typical PWM output from micro-computer IC. The following simplified PWM output configuration is suggested :

The high input impedance of the volume control pin makes the input current extremely small, so that it is not necessary to have an external buffer at the PWM output.

Configuration A :

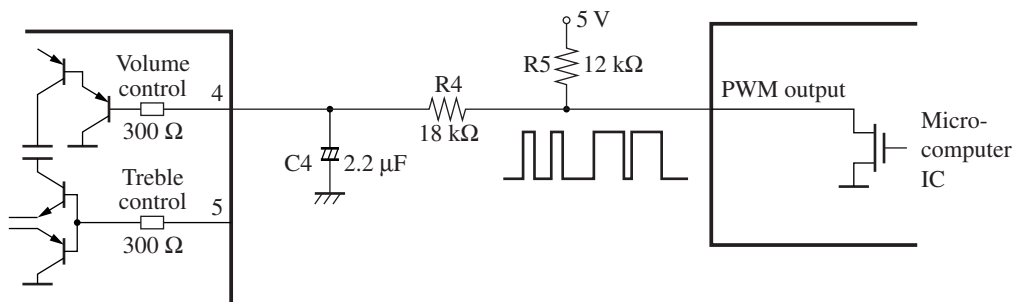

Fig. Volume control interface circuit for AN5270

## ■ Technical Information (continued)

### • Volume control (continued)

Alternative responses of volume control may be obtained by addition of a diode across the resistor R4.

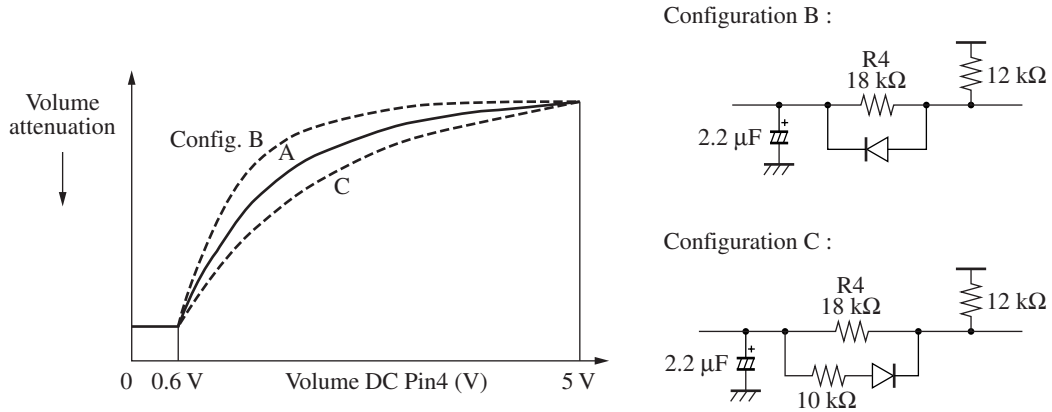

Fig. Volume characteristics of AN5270

### • Tone control

The tone control range is 0 to 5 V. Please adopt the same PWM configuration as suggested for the volume control.

The variable range of tone control is about 20 dB, depending on the values of R1 · C1 components that are connected to Pin3.

Internally, there is a LPF formed by  $R_i = 47 \text{ k}\Omega$  and a Miller capacitor which is formed by  $C_i = 33 \text{ pF}$  and the gain amplifier  $G = 40$ . The cut-off frequency is thus :

$$\frac{1}{2\pi \cdot G \cdot C_i \cdot R_i} = 2.5 \text{ kHz}$$

To achieve a rich deep-bass effect, the tone control should be adjusted to minimum (0 V). To achieve a bright treble effect, the tone control should be adjusted to maximum.

### • $V_{CC}$ requirement

$V_{CC1}$  should be fixed at 12 V. Achieve best performance by obtaining this supply from a 12 V voltage regulator output.

## ■ Technical Information (continued)

### • Power-on/off pop-noise elimination

In most TV applications, it is observed that there is a short period of delay from power-on to the onset of sound. The purpose of power-on mute is to eliminate any unpleasant 'pop' noise (caused by transients) by effectively muting the power amplifier. In this IC, an internal mute is incorporated at the instant of power-on and power-off. The length of mute time depends on the value of the ripple filter condenser at Pin6. In the following diagram, the value of the condenser connected to RF pin (Pin6) is 47  $\mu\text{F}$ .

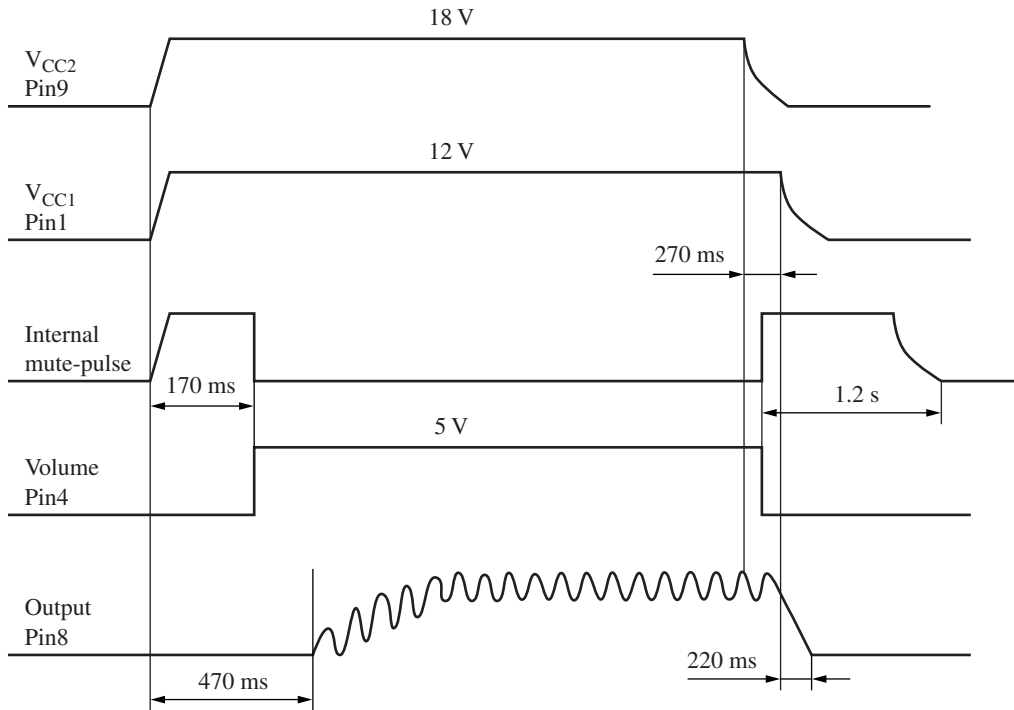

Fig. Power on/off typical timing characteristics of AN5270

(The above timing diagram is based on the evaluation circuit that is given in the product specification. Actual chasis performance may differ due to differences in power supply and external components.)

The internal mute pulse will force the volume to minimum by grounding Pin4 momentarily. In most chasis, it is also common to implement externally the audio defeat feature by forcing Pin4 to ground momentarily, for the purpose of power-on/off as well as during channel switching. Should the internal mute be insufficient, it is recommended that the external audio defeat be used.



### ■ Technical Information (continued)

- Power-off pop-noise countermeasure (for study consideration only)

To prevent power-off shock noise, please ensure that  $V_{CC2}$  (18 V) declines faster than  $V_{CC1}$  (12 V). In addition, to ensure that  $V_{CC1}$  variation will not cause any 'pop', one suggested countermeasure is to connect a condenser between Pin6 and Pin9 (e.g. 47  $\mu\text{F}$ , use non-polarity type if possible).

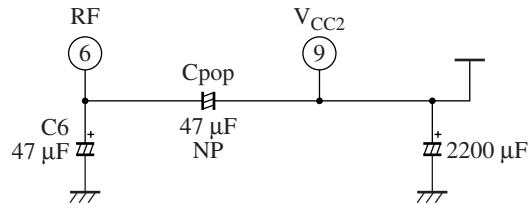

Fig. One suggested counter-measure against power-off 'pop' for AN5270.

This effect of  $C_{pop}$  is to discharge  $C_6$  gradually as soon as power is switched off.

However, it must be noted that the necessity of this countermeasure is dependent upon the set design and other timing considerations.

- THD improvement (for study consideration only)

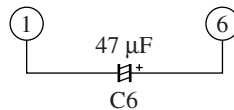

Fig. THD improvement circuit.

Instead of connecting the negative terminal of  $C_6$  to ground, when that terminal is connected to Pin1, it is noticed that THD is improved considerably.