

Installation Instructions for the TD Series Temperature Sensors

ISSUE 2
PK 87786

GENERAL INFORMATION

Each TD sensor includes a 0.040 x 0.050" silicon sensing element. The element is a laser trimmed thin-film resistive network, calibrated for sensor-to-sensor interchangeability.

TD4 sensors are designed for liquid temperature sensing. **TD4A** is a two-terminal threaded anodized

aluminum housing. **TD4S** is a two-terminal stainless steel housing with a hex head and pipe thread fitting.

TD5A is a miniature plastic package designed for small size and low cost.

NOTICE

Do not exceed electrical ratings.

ABSOLUTE MAXIMUM RATINGS

Operating Temperature	-40 to +150°C (-40 to +302°F)
Storage Temperature	-55 to +170°C (-67 to +338°F)
Voltage	10 VDC Continuous (24 hours)

INTERCHANGEABILITY (with 1 mA maximum current)

Temperature		Resistance (Ω)	Temperature		Resistance (Ω)
°C	°F		°C	°F	
-40	-40	1584 ± 12 (1.9°C)	+60	140	2314 ± 9 (1.1°C)
-30	-22	1649 ± 11 (1.7°C)	+70	158	2397 ± 10 (1.2°C)
-20	-4	1715 ± 10 (1.5°C)	+80	176	2482 ± 12 (1.4°C)
-10	14	1784 ± 9 (1.3°C)	+90	194	2569 ± 14 (1.6°C)
0	32	1854 ± 8 (1.1°C)	+100	212	2658 ± 16 (1.8°C)
+10	50	1926 ± 6 (0.8°C)	+110	230	2748 ± 18 (2.0°C)
+20	68	2000 ± 5 (0.7°C)	+120	248	2840 ± 19 (2.0°C)
+30	86	2076 ± 6 (0.8°C)	+130	266	2934 ± 21 (2.2°C)
+40	104	2153 ± 6 (0.8°C)	+140	284	3030 ± 23 (2.4°C)
+50	122	2233 ± 7 (0.9°C)	+150	302	3128 ± 25 (2.5°C)

Equation for computing resistance:

$$R_T = R_0 + (3.84 \times 10^{-3} \times R_0 \times T) + (4.94 \times 10^{-6} \times R_0 \times T^2)$$

R_T = Resistance at temperature R

R_0 = Resistance at 0°C

T = Temperature in °C

ELECTRICAL INTERFACING

Figure 2 is a simple circuit that can be used to linearize the voltage output to within 0.2% or a ± 0.4°C error over a range of -40 to +150°C (-40 to +302°F).

Figure 3 illustrates one method of detecting one particular temperature. The potentiometer in the comparator circuit can be adjusted to correspond to the desired temperature.

Figure 1
Resistance vs Temperature

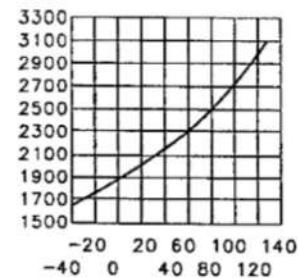

Figure 2
Linear Output Voltage Circuit

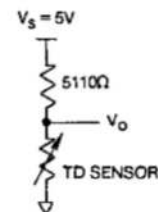
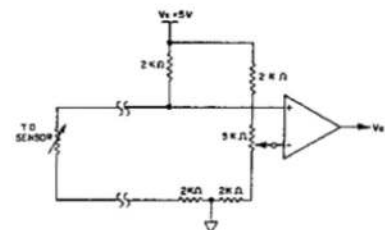
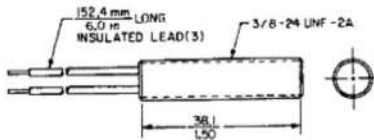

Figure 3
Adjustable Point (Comparator) Circuit



MOUNTING DIMENSIONS (for reference only)

TD4A



TD4S

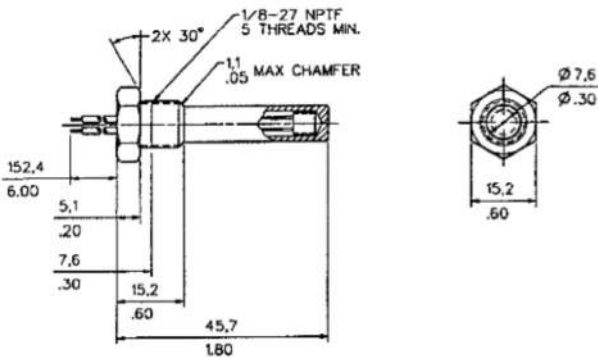

TD5A

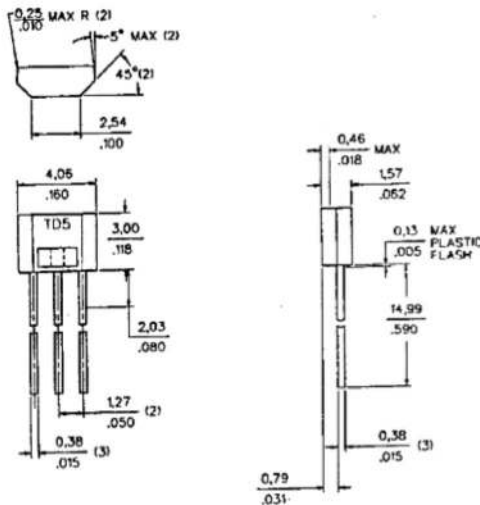

SOLDERING INSTRUCTIONS

Hand soldering: use 60/40 rosin core solder, and a 399°C (750°F) controlled temperature, 1/8" chisel tip soldering iron. Do not hold iron on the terminals for more than 4 seconds (solder pads, 3 seconds) to avoid delamination of terminals from ceramic. The temperature of the lead at the ceramic conductor must not exceed 250°C (482°F).

Wave soldering: use Loncoflux 106A35 or equivalent. Preheaters should be set for 95°C (200°F) on top (component side) of PC board just prior to board entering wave. (This may have to be adjusted depending upon board thickness.) Solder temperature should be 260°C (500°F) maximum, preferably 252 to 260°C (485 to 500°F). Set conveyor speed to approximately 4.5 feet per minute (1.37 meter/min.). Select a speed which gives full solder fillets and a minimum of bridging and icicles. The printed circuit board requires rigid support during wave soldering.

CLEANING

Proper cleaning fluids should be selected, based on the type of contaminants to be removed. MICRO SWITCH recommends use of the following:

- Alcohols
- Chlorinated solvents
- Fluorinated solvents.

WARRANTY/REMEDY

Honeywell warrants goods of its manufacture as being free of defective materials and faulty workmanship. Commencing with date of shipment, Honeywell's warranty runs for 18 months. If warranted goods are returned to Honeywell during that period of coverage, Honeywell will repair or replace without charge those items it finds defective. The foregoing is Buyer's sole remedy and is in lieu of all other warranties, express or implied, including those of merchantability and fitness for a particular purpose.

While we provide application assistance, personally and through our literature, it is up to the customer to determine the suitability of the product in the application.

Honeywell

Sensing and Control
Honeywell Inc.
11 West Spring Street
Freeport, Illinois 61032



Printed with Soy Ink
on 50% Recycled Paper

PK 87786-2-EN IL50 GLO 0303 Printed in USA

www.honeywell.com/sensing